

[CONTRIBUTION FROM THE KENT CHEMICAL LABORATORY OF THE UNIVERSITY OF CHICAGO]

## A METHOD FOR PHOTOGRAPHING THE DISINTEGRATION OF AN ATOM, AND A NEW TYPE OF RAYS<sup>1</sup>

BY WILLIAM D. HARKINS AND R. W. RYAN

Received June 25, 1923

### Introduction

In 1915 Harkins and Wilson<sup>2</sup> published the first definite theory of the composition of the nuclei of atoms in terms of hydrogen and helium. The theory predicted a general difference of stability between the atoms of elements of even and those of odd atomic number. That this prediction is definitely confirmed was shown in a later paper,<sup>3</sup> where it was demonstrated that (1) the elements of even atomic number are represented in the meteorites by 70 times as many atoms as those of odd number; (2) every one of the 7 most abundant elements in the meteorites has an even atomic number; (3) every one of the 5 undiscovered elements has an odd atomic number, and (4) there are many more atomic species (isotopes) of even than of odd atomic number.<sup>4</sup>

An altogether different type of confirmation was supplied later by Rutherford.<sup>5</sup> He was able to disintegrate atoms of the elements 5, 7, 9, 11, 13 and 15, in such a way that they give off hydrogen in every case, while he did not obtain any evidence that atoms of elements of even atomic number disintegrate at all. Now, the theory of Harkins specifically pointed out that the energy of combination of hydrogen to form helium is so great that a disintegration of any atom built up entirely of helium would probably in no case give hydrogen (Table I), but it indicated that elements of odd atomic number contain hydrogen not combined into

<sup>1</sup> Presented at the Intersectional Meeting of the American Chemical Society, Urbana, Ill., May 4, 1923.

Parts of this paper have been presented or photographs of  $\alpha$ -ray tracks have been exhibited at the following meetings: American Chemical Society, Pittsburgh, September, 1922; American Physical Society, Chicago, November, 1922; Washington, April, 1923; Section C., A. A. A. S., Boston, December, 1922. Letters concerning the work, with photographs, have been published in *Nature*, **111**, 27 (Jan.), 1923, and **112**, 54 (July), 1923.

Presented by R. W. Ryan as a thesis in partial fulfilment of the requirements for the degree of Doctor of Philosophy at the University of Chicago.

<sup>2</sup> Harkins and Wilson, *Proc. Nat. Acad. Sci.*, **1**, 276 (1915). *THIS JOURNAL*, **37**, 1367 (1915).

<sup>3</sup> Harkins, *THIS JOURNAL*, **39**, 856 (1917).

<sup>4</sup> That this follows from the theory of Harkins was shown by N. F. Hall [*Ibid.*, **39**, 1606 (1917)].

<sup>5</sup> Rutherford, *Phil. Mag.*, **37**, 538 (1919). Rutherford and Chadwick, *ibid.*, **42**, 809 (1921).

helium, and these would thus be capable of disintegration to give hydrogen,<sup>6</sup> as accords with the experimental results.

TABLE I  
ENERGY OF ALPHA-PARTICLES

Energy of formation of 1 g.-atom of helium from 4 g.-atoms of hydrogen =  $-2.8 \times 10^{10}$  ergs. ( $-4.6 \times 10^{-5}$  ergs per atom of He)

Source of $\alpha$ -particle	Velocity	Kinetic energy,	
		Per particle $\times 10^6$	Per gram atom $\times 10^{-18}$
Po	0.0523 c	0.812	4.92
Ra C'	.0641	1.218	7.38
Th C	.0572	0.970	5.88
Th C'	.0688	1.404	8.51

The table indicates that the highest kinetic energy for any of the  $\alpha$ -particles listed is less than  $\frac{1}{3}$  the energy of formation of an  $\alpha$ -particle from protons and electrons.

"c" is the velocity of light.

The scintillation method as used in these experiments by Rutherford, is capable of detecting disintegration particles which have only a range greater than 30 cm. in air, since hydrogen atoms which are merely released from chemical combination in water, hydrogen, and other compounds, have nearly this range, while  $H^+$  particles (protons) released from the nucleus of an atom have a greater range. In the case of the aluminum nucleus, for example, it is 90 cm. However, other disintegrations may occur. Thus, when bombarded by swift  $\alpha$ -particles, certain atom nuclei may give disintegration fragments, such as  $\alpha$ -particles,  $H^+$  particles, or electrons, of a shorter range than 30 cm. Since all such particles, of any range down to less than a millimeter, leave visible tracks in the ray track apparatus of C. T. R. Wilson,<sup>7</sup> it would seem that a method could be devised which would utilize this apparatus for the detection and study of nuclear disintegrations induced by the impact of swift  $\alpha$ -particles, provided the characteristics which such a disintegration would exhibit could be determined, and to do this is very simple.

#### Photographs of Atomic Collisions. (Collisions of the Nuclei of Atoms)

In order to disintegrate an atom nucleus artificially it is necessary to bombard it with a high-speed helium nucleus ( $\alpha$ -particle).<sup>8</sup> The scintillation experiments of Rutherford,<sup>9</sup> and of Geiger and Marsden<sup>10</sup> have shown that the  $\alpha$ -particle must pass through an extremely great number of atoms

<sup>6</sup> In the 1915 paper from this Laboratory it was pointed out that the packing effect for hydrogen nuclei in a complex nucleus is smaller in all probability when the hydrogen is not combined in an  $\alpha$ -particle. The atomic weight of nitrogen, 14.01, indicates that this is true in the nitrogen nucleus unless the 0.01 in excess over a whole number is due to experimental error.

<sup>7</sup> Wilson, *Proc. Roy. Soc.*, **87**, 277 (1912).

<sup>8</sup> It is of course possible that high-speed electrons may also induce disintegration.

<sup>9</sup> Rutherford, *Phil. Mag.*, **21**, 669 (1911).

<sup>10</sup> Geiger and Marsden, *Proc. Roy. Soc.*, **82A**, 495 (1909).

in order to secure a single collision with the nucleus of an atom, and the photographs described in the present paper demonstrate this in a much more direct way.

The writers have taken 21,000 photographs of  $\alpha$ -ray tracks in air and a few in helium and ethyl chloride. Of these 10,000 were secured by using polonium, and 11,000 by using thorium C and C' as the source of the  $\alpha$ -particles. In all, about 80,000 tracks have been photographed. In each of these the  $\alpha$ -particle passes directly through between 100,000 and 200,000 atoms, provided atoms have the dimensions usually attributed to them. In all about 12 billion atoms have been shot through, with the remarkable result that in only 3 cases has the nucleus of an atom of the

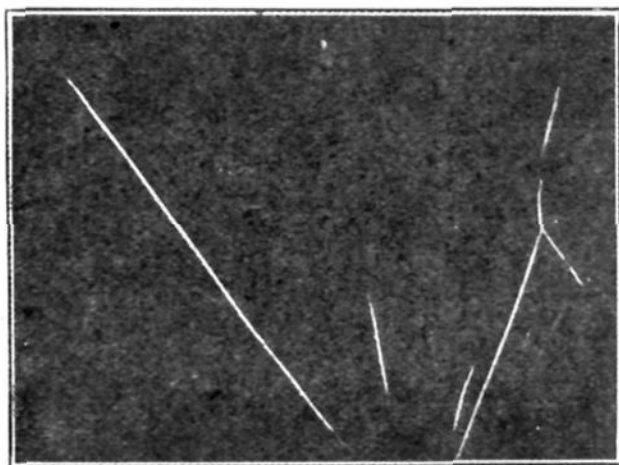

Fig. 1.—Sharp atomic collision with a visible track of the bombarded nitrogen or oxygen nucleus. The fork exhibits conservation of momentum which proves that the nucleus remains stable under the impact

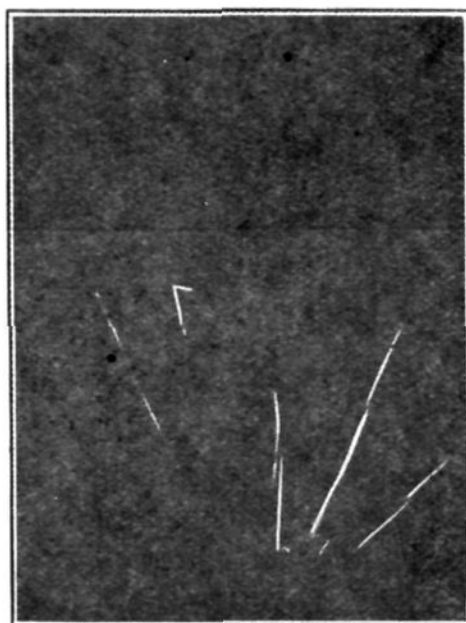

Fig. 2.—Atomic collision. Shows an apparent but not a real, contradiction of the principle of conservation of momentum

gas been hit sharply enough to give a *retrograde* motion to the  $\alpha$ -particle after the collision. Thus for each sharp collision the  $\alpha$ -particles have had to shoot through about 4 billion atoms. This fact taken alone would indicate that the radius of the nucleus of an atom of air<sup>11</sup> is of the order of  $\frac{1}{30,000}$  that of the atom, which would give the nucleus a radius of the order of a little more than  $10^{-13}$  cm. Since the number of hits is so small, a closer estimate could be secured by a consideration of the numerous cases in which the particle is slightly deflected from its path by the repulsion between its positive charge<sup>12</sup> of 2 and that of 7 on the nitrogen nucleus.

Fig. 1 gives a reproduction of a photograph of the sharpest nuclear

<sup>11</sup> An atom of nitrogen or oxygen.

<sup>12</sup> In this paper the charge on the electron is taken as of unit magnitude.

collision ever obtained, with one exception. The  $\alpha$ -particle from a polonium source, with an initial velocity of  $1.357 \times 10^{10}$  cm. per second, is turned through an angle of  $155^\circ$  and rebounds for a distance whose horizontal projection is about 5.2 mm. while the nitrogen nucleus is projected forward for a corresponding distance of 3.8 mm. If the track of this

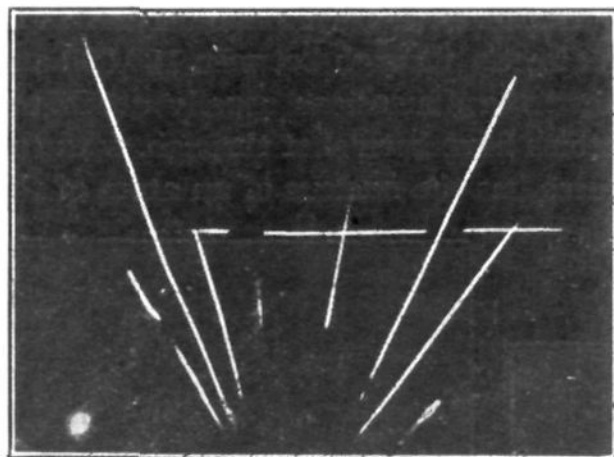

Fig. 3.—Effect of old tracks in the taking up of water vapor

nucleus is projected backward it may be seen that the line thus obtained lies slightly closer to the track of the on-coming, than to that of the retreating  $\alpha$ -particle. This is essential in order that the impact shall exhibit conservation of momentum, since the  $\alpha$ -particle has much less momentum after the collision than it had before.

The characteristics of an ordinary collision are: (1) the initial track splits into two branches,—that is, three lines converge at one point in space,—(2) momentum is conserved in the collision and (3) the three tracks lie in one plane. In addition, energy is conserved, provided the presumably small amount of energy radiated is taken into account.

Fig. 2 shows the third sharpest collision photographed, and is presented as an example of an apparent, but not a real, contradiction to the principle of conservation of momentum in an impact. Here the track of the bombarded nucleus does not appear in the photograph. Presumably this is due to a lack of water vapor for the production of the track. This often occurs and is due to a con-

version of the water vapor in a particular region into the minute drops which form a track. These drops are electrically charged and are drawn out of the gas by an electrical field of 500 volts per cm. If a second track passes through this region within a few tenths of a second there is not sufficient moisture to enable water to gather in drops on the ions, so there appears to be a break in the track. In one photograph (Fig. 3) there

Fig. 4.—Loop formed by two  $\alpha$ -ray tracks, showing old track threading the loop

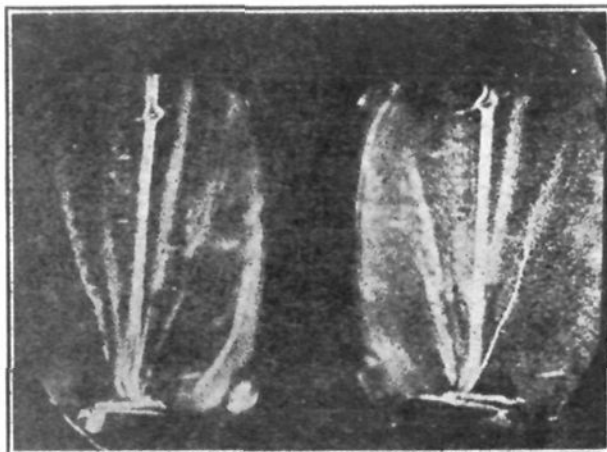

Fig. 4.—Loop formed by two  $\alpha$ -ray tracks, showing old track threading the loop

are two such breaks in a transverse track; one due to a track which has passed so recently that it appears very sharp, while the other is caused by an older track which has become diffuse and has been mostly swept out by the electric field. The transverse track was photographed almost immediately after its formation. If it had remained slightly longer, ions produced by the  $\alpha$ -particle would have diffused out (or have been pulled out by the field) of the dry region into a space which contains more moisture, and here an apparent loop somewhat like half of an ellipse cut along its longer axis would have appeared in the track. This bends either upward or downward corresponding to whether the new track lies above or below the old one. In some cases it bends in both directions, and the remnant of the old track is photographed as if threading the eye of a needle. (Fig. 4.)

### Characteristics Exhibited by a Photograph of the Disintegration of an Atom

In order to secure the transfer of a large amount of energy to the nucleus to be disintegrated, the incident  $\alpha$ -particle should have as high a speed as is possible, and also the collision should be as sharp as can be obtained. The former of these conditions was met in the experiments under discussion in this section, by the use of thorium C and C' as a source. Fig. 5 shows the sharpest collision ever photographed. The angle in space between the lines representing the tracks of the  $\alpha$ -particle is only  $15^\circ$ , so that the particle has been turned through an angle of  $165^\circ$ .

Where a nuclear collision occurs, the initial track splits into two branches. If it should split into three branches, one of these would be due to the rebounding  $\alpha$ -particle, one to the forward path of the nucleus which is hit, and a third track, provided it

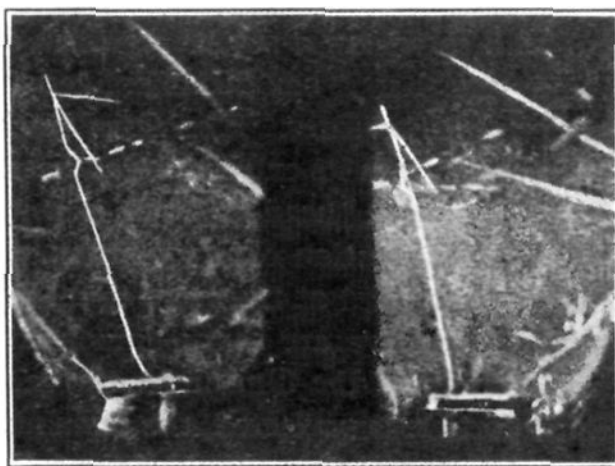

were due to a positively charged nucleus, would indicate a particle torn off from the bombarded nucleus by a process of disintegration. Now it happens that the tracks of positively charged nuclei are usually easily distinguished from those of negative electrons, since the latter are much fainter, and more highly curved. It might seem that the extra track was caused by the collision of the  $\alpha$ -particle with a second nucleus which is not very distant from the first one, but nuclear collisions are so rare that this

Fig. 5.—Sharpest collision of atomic nuclei photographed. Shows the number of tracks characteristic of an atomic disintegration

is extremely improbable. Even if it should occur, the momentum and energy relations are such as to give a type of double fork which could probably be recognized. Thus, the energy imparted to the nuclei would be taken from that of the  $\alpha$ -particle, so the latter should have a shorter range if it gives energy to a second nucleus than if it hits only one. The energy difference can be estimated, within rather wide limits, from the range of the nuclei that are hit. Even at such high speeds as those used in this work there should be no considerable departure from the principle of conservation of momentum in the combined impact and disintegration. Therefore, whenever all of the tracks show, the photograph should exhibit this conservation. However, Fig. 2 demonstrates that the track of even a highly charged positive nucleus may fail to appear. From this point of view it would not seem strange if the faint tracks due to high speed electrons or  $H^+$  particles should remain invisible.

If a disintegration should occur, the  $\alpha$ -particle and the bombarded nucleus alone would not be expected to exhibit conservation of momentum, though momentum is always conserved in a collision unaccompanied by a disintegration. This indicates that if the tracks of these particles as shown by the photograph are such that momentum is not conserved for the two particles alone, and atomic disintegration has taken place.

In a simple collision it is to be expected that all of the tracks should lie in a plane. If a disintegration occurs this should not be true except by accident.

Fig. 5 shows an  $\alpha$ -ray track which splits into 3 branches after the collision occurs, so it has this characteristic to be expected if the bombarded nucleus disintegrates. The extra track is too bright to be caused by an electron, though its extreme brightness is due to the fact that it is photographed almost "head-on." It is evident that the visible tracks do not exhibit conservation of momentum, which may indicate that other particles are emitted at the same time, but do not show. The tracks in the original negative are sharp—much sharper than in the reproduction,—and a study of the film under the microscope seems to show that if the third particle is neglected, the remaining tracks do not show conservation of momentum as they should if the collision is a simple one. The question arises, could the extra track have been formed by the disintegration of a radioactive particle exactly at the point of collision at almost exactly the time of the collision? It cannot be stated that this is an absolute impossibility, but it is certain that the probability of such a coincidence is excessively small. At any rate the method used in these experiments will in general photograph atomic disintegrations if they occur.

#### Zeta ( $\zeta$ ) Rays

Delta( $\delta$ )-rays were first found in gases by Bumstead, who gave them a sufficient range for observation by causing them to appear in hydrogen

at low pressures. The rays are given off at nearly right angles to the track of the  $\alpha$ -ray which produces them. They are very short in air at ordinary pressure, not more than 0.5 mm. in length, and end in a knob which is easily visible. It is supposed that they are produced by low speed electrons removed from the atoms by the passage of the particle. C. T. R. Wilson has secured beautiful photographs of these rays, and the writers have often observed them, particularly in helium.

Fig. 6 shows a new type of rays, which may be called zeta ( $\zeta$ ) rays. Their range is very many times greater than that of the  $\delta$ -rays. They are much rarer, and give faint, but very definite tracks. Their faintness and high curvature makes it seem probable that they are due to electrons torn out of the

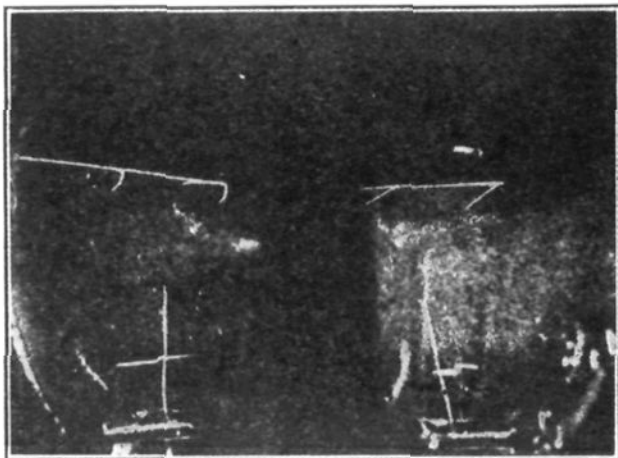

Fig. 6.—Rays of a new type (Zeta Rays). Probably due to electrons

atoms, possibly from the K level. The figure indicates that the ejection of the first  $\zeta$ -ray does not materially change the direction of the  $\alpha$ -ray track, and this, taken in connection with the length of the tracks shows that the mass of these particles must be low, as would be the case if they are electrons.

These rays present features of extreme interest.<sup>13</sup> Thus in Fig. 6 the

<sup>13</sup> In a letter in *Nature*, **111**, 463 (April 7, 1923), Bose and Ghosh present three interesting photographs of  $\alpha$ -ray tracks in helium. The interpretation of these photographs is difficult, since only one projection was obtained, but it seems that electrons have been ejected from helium atoms by the passage near or through them of  $\alpha$ -particles. In this respect there is some similarity to what has been discussed above under the designation of  $\zeta$ -rays. However, their rays possess quite different characteristics, since they are not projected backward. In order to determine the nature of the rays secured by them two projections should be obtained, since one projection may reveal entirely different characteristics from those exhibited by the other.

Their photographs do not resemble those which depict the collision of 2 atom nuclei, since in each case there seems to be a continuation in a straight line of the initial  $\alpha$ -ray track beyond the point where the branching occurs.

Since the nucleus of the **argon** atom is larger, and the electric field around it is also stronger, than for nitrogen or **oxygen**, it is much easier to secure photographs of atomic collisions in argon than in either of the two other gases. Blackett [*Proc. Roy. Soc.*, **103A**, 62 (1923)] obtained one collision in which the  $\alpha$ -particle from polonium was turned through an angle of about  $110^\circ$ , but this is much less sharp than those given in Fig. 1 ( $125^\circ$ ) and in Fig. 3 ( $165^\circ$ ).

In addition to the 21,000 photographs of  $\alpha$ -ray tracks in air described in the body of the paper, the writers have now obtained about 20,000 photographs of tracks in argon.

2 ray-tracks are practically parallel. Both start upward and give curves that are convex upward. The particles have a considerable retrograde motion, and their range is about 3 mm.

Of these, two are so remarkable that they are presented in Figs. 7 and 8. One of these, Fig. 7, represents by far the most remarkable simple collision yet obtained, in that the



Fig. 7.—Collision of fast  $\alpha$ -particle with the nucleus of an argon atom. The hardest hit thus far photographed. The fork exhibits conservation of momentum, which proves that the argon nucleus has not disintegrated

$\alpha$ -particle from a source consisting of thorium C and thorium C' strikes an argon nucleus and is deflected diagonally upward through more than  $45^\circ$ . Two other tracks spring from the point of collision, as is made evident by the two projections which go more or less downward. As nearly as can be told, there is a total conservation of momentum in the impact. The appearance of the two tracks for the bombardment nucleus instead of one indicates that (1) the argon nucleus disintegrates, or (2) the bombarded argon nucleus collides with a second argon nucleus within 0.5 mm. of its starting point. There is a third possibility, that the  $\alpha$ -particle hits 2 argon nuclei in direct succession, but the probability of such an occurrence is almost negligible. The angle between the two tracks under discussion is about  $80^\circ$ . From the 20,000 photographs of  $\alpha$ -ray tracks in argon, and by a consideration of the stopping power of argon, it has been calculated that the probability that an argon nucleus will hit a second argon nucleus within a distance of 0.5 mm. in such a way as to give an angle as great as  $80^\circ$  between them, is small, possibly about 1 in 1000, the most uncertain factor being that

speed of the  $\alpha$ -particle is far higher than for any previous case. Thus, even *after* the loss of a considerable fraction of its energy by collision with an argon nucleus, the velocity of the rebounding  $\alpha$ -particle is nearly  $1/20$  that of light, or 18,000 times that of the fastest rifle bullet. The range of the argon nucleus in argon is very high, about 8 or 9 mm. under the conditions of the experiment. The most remarkable feature of this photograph is that it shows that even under this terrific impact the argon nucleus remains intact, so its stability must be of an extremely high order. The  $\alpha$ -particle in question has its source in thorium C', so its initial velocity is 0.688 c.

A nuclear collision which is not simple is represented in Fig. 8. An

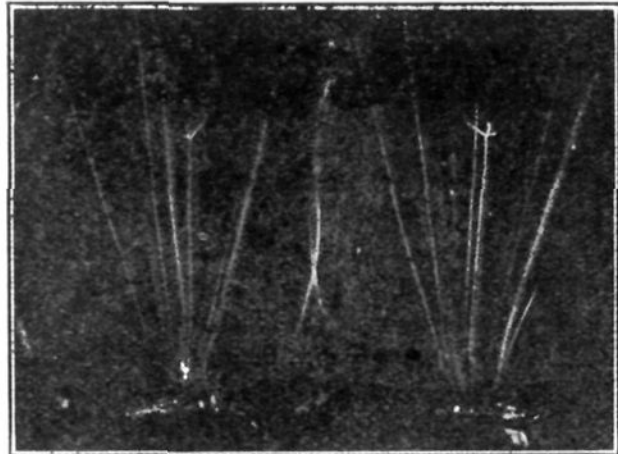

Fig. 8.—Double collision of atom nuclei in argon. The  $\alpha$ -particle collides with the nucleus of an argon atom, and probably this in turn collides with a second argon nucleus. Both views of the collision are clear in the original photographs



### Experimental Part

The apparatus used is shown in Figs. 9, 10, and 11.

It is essentially a modified Shimizu-Wilson apparatus,<sup>14</sup> and consists of a glass cloud chamber N (Fig. 9) fitted with a piston and provided with a means for securing a sudden expansion. The roof of this cloud chamber is a glass plate K coated underneath with moist gelatin to which copper sulfate has been added. The top of the piston is also coated with moist gelatin blackened with india ink (not waterproof). A source of  $\alpha$ -rays is provided at one side of the chamber as shown in Fig. 11 (B). Electrons given off and ions formed by the passage of  $\alpha$ -particles through a gas serve as nuclei for the formation of water drops during the expansion and consequent cooling of the nearly saturated gas. A motion picture camera A is provided with a driving mechanism and an optical system such as to take views at right angles at the end of each expansion.

The most important modifications of the original Shimizu-Wilson Apparatus and the method of securing the rays are: (1) the use of a standard

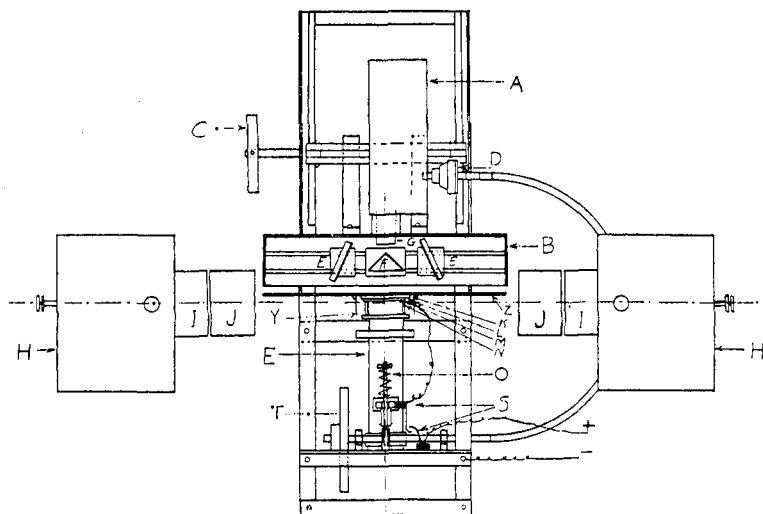

Fig. 9.—Front view of ray track apparatus

motion picture camera driven by a flexible shaft (A, Figs. 9 and 10); (2) a special cam R (Fig. 10) used to secure a sudden expansion (a related to the speed of the argon nucleus). Nevertheless, the characteristics of the tracks around the point of impact suggest that this double collision is probably what has occurred. The shortness of the two tracks, and their approximate equality in length seem to point to the conclusion that in this case a disintegration has not occurred. That the two short prongs are not due to electrons is indicated by the fact that the  $\alpha$ -particle is deflected too sharply to give conservation of momentum with such light particles. Thus it seems probable that Fig. 8 represents the first "double collision" of atom nuclei to be photographed, though the possibility that the argon nucleus has disintegrated is not at all excluded. (Received August 9, 1923.)

<sup>14</sup> Shimizu, *Proc. Roy. Soc. (London)*, **99A**, 425 (1921).

somewhat similar device is used by Blackett<sup>15</sup>); (3) the use of ThC, ThC', and RaC as source of  $\alpha$ -rays; (4) the electric field used to sweep out water drops between the expansions is applied by means of brush contacts S instead of by a commutator; (5) a variable voltage transformer and a 500 volt kenotron (with a 1mf. condenser) is used as a source of this field; (6) the use of a moving screen prevents  $\alpha$ -particles from entering the chamber except during maximum expansion.

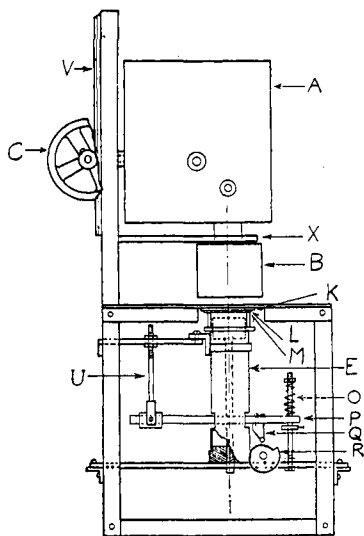

Fig. 10.—Side view of ray track apparatus

A is a copper strip used as a screen to prevent rays from entering the chamber except at the time of maximum expansion and B is a Bakelite block holding the copper wire carrying the active deposit. This is so bored that  $\alpha$ -particles are able to shoot out in only a narrow beam;  $\alpha$ -particles shot out at other times than at maximum expansion give diffuse tracks.

ThC and ThC' served as the source of the  $\alpha$ -particles for much of this work. About 1 mg. of radiothorium is first dissolved in concd. hydrochloric acid. Then a copper wire is coated with wax, except at one end, and immersed in this solution for about half an hour or longer if the solution is weaker. The "active deposit" of thorium, consisting largely of ThC and ThC', deposits (by displacement) on the exposed copper. The end of the wire is then cut off and placed at the base of the Bakelite block (B, Fig. 11).

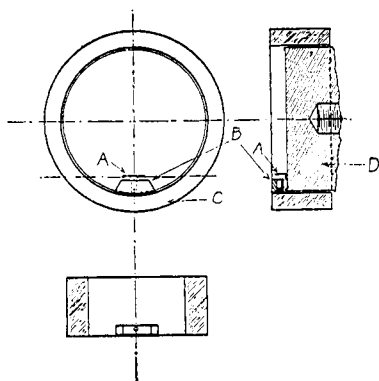

Fig. 11.—Diagram of ionization chamber

The very short life of ThC (only a few hours) makes it necessary to prepare this source immediately before use. Polonium sources are prepared in a similar way from solu-

<sup>15</sup> Blackett, *Proc. Roy. Soc.*, 102A, 294 (1922).

tions of RaF in hydrochloric acid but have a life measured in months instead of hours.

The photographic equipment includes a motion picture camera (A, Fig. 9) driven by a flexible shaft which carries a clutch D and thus allows the timing of the shutter with the expansion. This camera is provided with a Taylor-Hobson-Cooke F/2 lens in a focusing mount G, and an optical system which consists of two adjustable surface silvered mirrors E, and a prism F. These mirrors are carried on a 3-point support that slides along a track shown in Fig. 9, while the prism is clamped directly below the lens.

The cloud chamber is illuminated by two d. c. right-angle arcs, each provided with an 11cm. aspheric condenser and a cooling cell. Ammeters are used in both circuits and the current is adjusted so as to afford uniform illumination. Slits are provided on the cooling cell J and at Y in order to prevent the beam of light from striking the lower surface of the glass roof of the cloud chamber or the top of the piston at the moment of expansion.

In both views parts of the frame, the driving apparatus, etc., have been left out so that a clearer view of the essential parts of the apparatus could be given.

For a successful photograph a very sharp expansion is necessary, so that a fairly heavy spring O is used to force down the piston immediately upon its release by the cam R (Fig. 10). Means are provided for varying the length and the height of the stroke at U, and a locknut just below P regulates the expansion ratio. Somewhat exact adjustment is required to give the optimum conditions. A monatomic gas such as helium or argon requires a small expansion to secure the necessary cooling; air (nitrogen and oxygen) and other diatomic gases require a somewhat greater expansion, and a polyatomic gas such as ethyl chloride requires so great an expansion that it is difficult to prevent leakage into the apparatus. In the latter case the leather gasket of the piston must also be lubricated with some material not soluble in ethyl chloride (as glycerol and graphite).

The writers wish to thank the Visual Education Society for the use of one of their motion picture cameras; the Gibb's Fund of the National Academy of Sciences for a grant partly used in this work; Dr. H. N. McCoy for the polonium used and for the loan of radium; Dr. H. S. Miner of the Welsbach Company, for the loan of mesothorium and radiothorium; Mr. Henry Burke, of Burke and James, Chicago, for aid in securing the remarkably fine lens used; and Mr. Paul L. Gross for assistance in the photographic work.

### Summary

1. The *rarity* of a collision between a fast helium nucleus ( $\alpha$ -particle) and the nucleus of an atom in a gas through which it is passing, *increases*

*greatly as the directness of the collision increases.* At the time of the beginning of the experimental work described in the present paper no photograph of a collision had been obtained sufficiently sharp to give the helium nucleus ( $\alpha$ -particle) a retrograde motion after the collision. Thus far photographs have been taken of enough tracks so that the  $\alpha$ -particles have passed through about 12 billion atoms in air, with the result that in only 3 cases has such a rebound been obtained. This alone would indicate that the nucleus of an atom of nitrogen or oxygen is of the order of slightly more than  $10^{-13}$  cm. in radius. A more accurate value can be obtained by a mathematical analysis of all of the deflections of the  $\alpha$ -particle through smaller angles.

2. In an ordinary collision 3 tracks meet in a point: one for the  $\alpha$ -particle before, and a second for the same particle after the collision. If the bombarded nitrogen or oxygen nucleus should disintegrate, then at least 4 tracks should meet, the additional track being due to a fragment, such as an electron, a hydrogen or a helium nucleus, disrupted from the bombarded nucleus. The chance of such a disintegration increases rapidly with the directness of the collision, and with the speed of the  $\alpha$ -particle. For some unknown reasons the tracks of high-speed  $\alpha$ -particles have not been photographed in previous work. While using such high-speed particles the writers secured a remarkable photograph of by far the most direct nuclear collision recorded in this way up to the present time, with the result that a fourth track, which should characterize an atomic disintegration, appeared in the photograph. That this track springs from the proper point in space is shown by the two projections obtained simultaneously. These give two views at an angle of  $90^\circ$ . Whatever may be the final decision with respect to this individual photograph, the method presented in this paper will reveal atomic disintegrations to give either helium or hydrogen or electrons, provided they occur during the operation of the apparatus, though the labor and expenditure of funds involved in obtaining such photographs may prove to be very great.

3. Rays of a new type, designated by the writers as zeta ( $\zeta$ ) rays, are shown in Fig. 6. Here the  $\alpha$ -particle evidently drives particles from 2 widely separated atoms in its path. It is remarkable that the two tracks thus obtained lie in almost parallel planes, both are highly curved and almost parallel lines, and both have a sharp retrograde motion. It seems probable that the  $\zeta$ -rays are due to electron emission, but this is not certain. The particles must be very light, however, since the direction of the  $\alpha$ -particle is not materially affected by the emission, and the tracks of the particles are moderately long, very much longer than those of the previously recorded  $\delta$ -rays.

4. Thus far, 40,000 photographs have been secured, and 3,000 photographs are obtained for each additional hour of operation of the apparatus

with photographic attachments. A number of collisions have been observed visually during periods when the camera is not in use.

5. The method presented in this paper is being used to test experimentally the stability of atom nuclei. Such tests have not been made before. Rutherford's experiments, for example, reveal the disintegration of an extremely minute number of atoms to give long range hydrogen particles, but they do not show whether or not  $\alpha$ - or any other short range particles are emitted. The difficulty of the present method lies in the small number of direct hits obtained. Less direct impacts are relatively numerous.

The remarkable feature of the present work is that in no case has any one of these oblique impacts effected a disintegration of the nucleus. Even more remarkable is the fact that the argon nucleus in Fig. 7 remains intact even under the sharp impact of a helium nucleus from 'Thorium C' ( $\alpha$ -particle) with a velocity of 25,000 or 30,000 times that of the swiftest rifle bullet, immediately before impact. This is evidenced by the fact that the visible tracks around the point of collision exhibit conservation of momentum. Fig. 1 illustrates the stability of an atom of air (nitrogen or oxygen) in exactly the same way except that the velocity of the  $\alpha$ -particle just before impact is not quite so high.

It may be added that the photographs chosen for this paper have been selected altogether from the standpoint of the importance of the events they represent, even although they may not be so good as some of the others from the purely photographic viewpoint.

CHICAGO, ILLINOIS

---

[CONTRIBUTION FROM THE RESEARCH LABORATORY OF PHYSICAL CHEMISTRY,  
MASSACHUSETTS INSTITUTE OF TECHNOLOGY, No. 152]

## THE EQUATION OF STATE FOR PURE NITROGEN, GAS PHASE<sup>1</sup>

BY LEIGHTON B. SMITH AND ROBERT S. TAYLOR

Received June 25, 1923

Following the method of Keyes, pure nitrogen has been investigated by the isometric method. The theoretical work in connection with the equation of state<sup>2,3,4,5</sup> has made it appear highly probable that in the

<sup>1</sup> This investigation was undertaken by the Research Laboratory of Physical Chemistry at the request of the Bureau of Mines, working in coöperation with the War and Navy Departments. The Bureau of Mines as well as the Massachusetts Institute of Technology contributed liberally in funds needed to carry forward the work.

The present paper is the fourth published by this Laboratory presenting data required in perfecting the processes for the extraction of helium from natural gas.

<sup>2</sup> Phillips, (a) *J. Math. Phys., Mass. Inst. Techn.*, **1**, 42 (1921); (b) *Proc. Nat. Acad. Sci.*, **7**, 172 (1921).

<sup>3</sup> Keyes, *THIS JOURNAL*, **43**, 1452 (1921).

<sup>4</sup> Keyes, *J. Math. Phys., Mass. Inst. Techn.*, **1**, 89 (1922).

<sup>5</sup> Keyes, *Proc. Nat. Acad. Sci.*, **3**, 323 (1917).